

# Shuttle Liquid Hydrogen (LH2) Engine Cut-Off (ECO) System Anomaly

**Presenter:**

**Michael D Stirling**

**NASA Electrical Systems**

**Lead Shuttle Electrical Power**

**Distribution & Control Engineer**

- System Overview
- Nominal Test and Checkout
- History
- Troubleshooting
- Root Cause
- The Fix
- System Improvements

# ECO System Overview

- The ECO sensors operate much like the "gas low" warning light in an automobile. When the fuel level drops below a sensor, that sensor sends a message to the orbiter's computer that it is dry.
- Orbiter computers poll these sensors about 8-12 seconds prior to planned Main Engine Cutoff, or MECO, which is about 8.5 minutes after launch.
- If two of the four ECOs transition from 'wet' to 'dry', which means the tank is almost empty, the space shuttle main engines will be immediately shut down. If the main engines are shut down prior to normal operating time, it could affect whether or not the shuttle reaches the appropriate orbit.

# Orbiter ECO Sensor Cable Routing

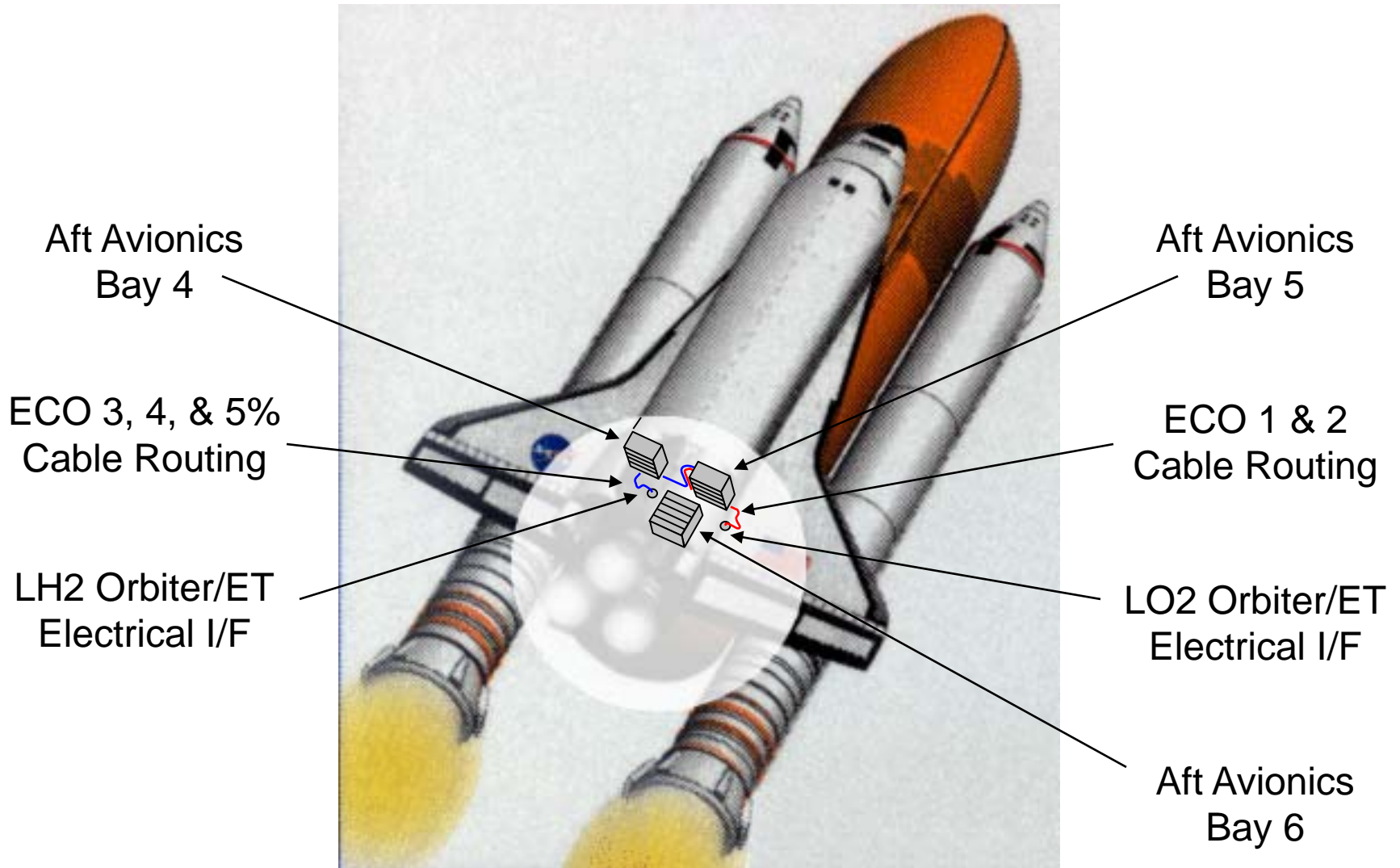

# LH2 ECO Circuit Diagram

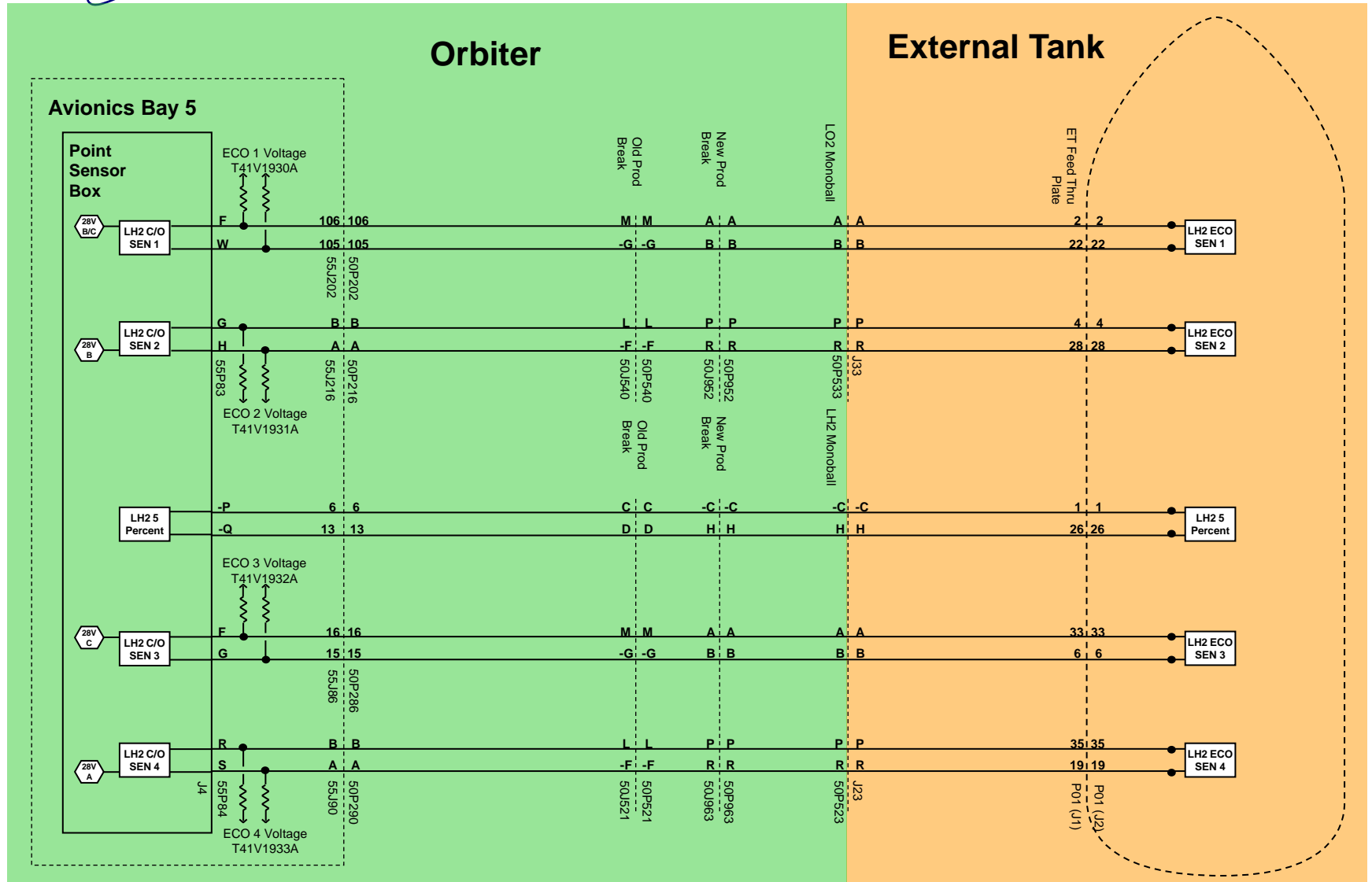

# Point Sensor Box Location

## Point Sensor Electronics Box

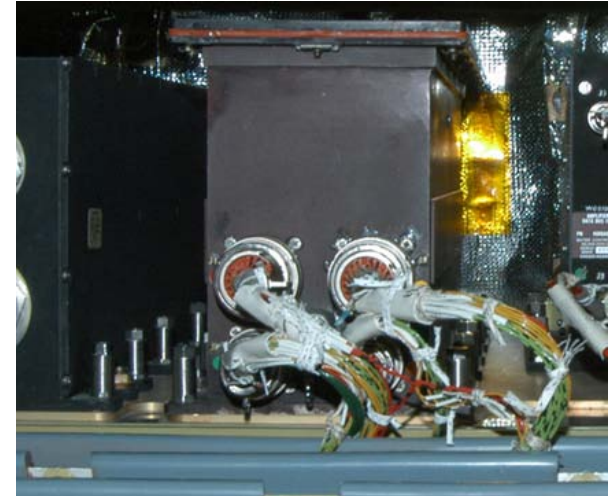
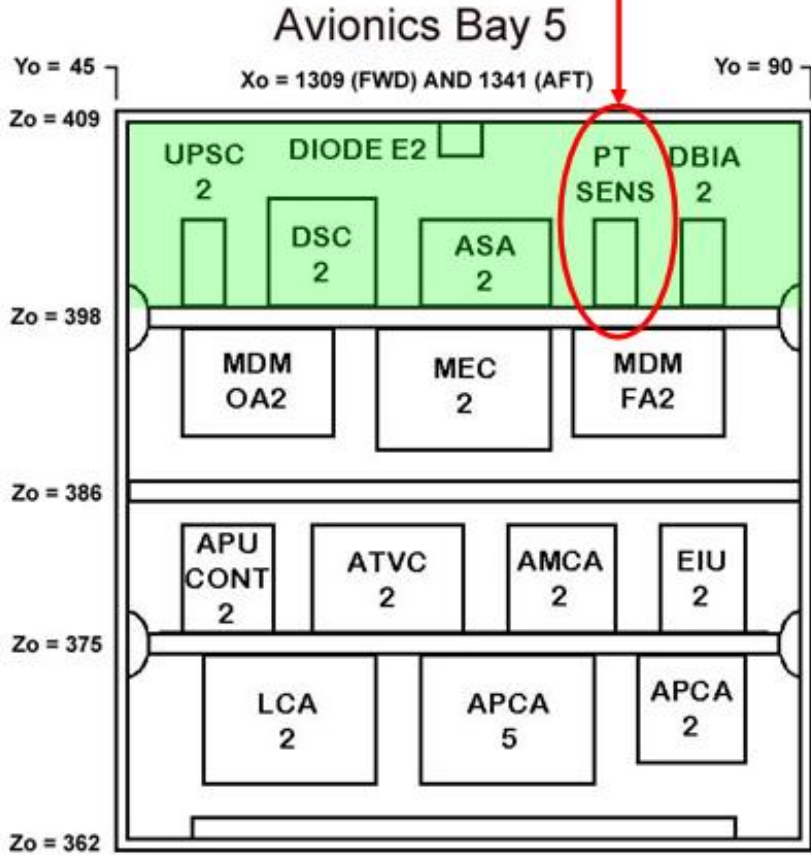

Point Sensor Box

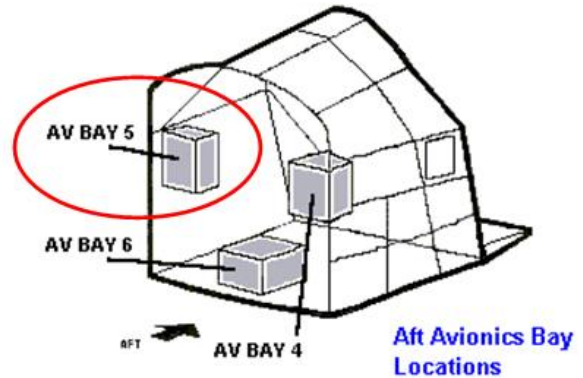

# External Tank Connector Locations

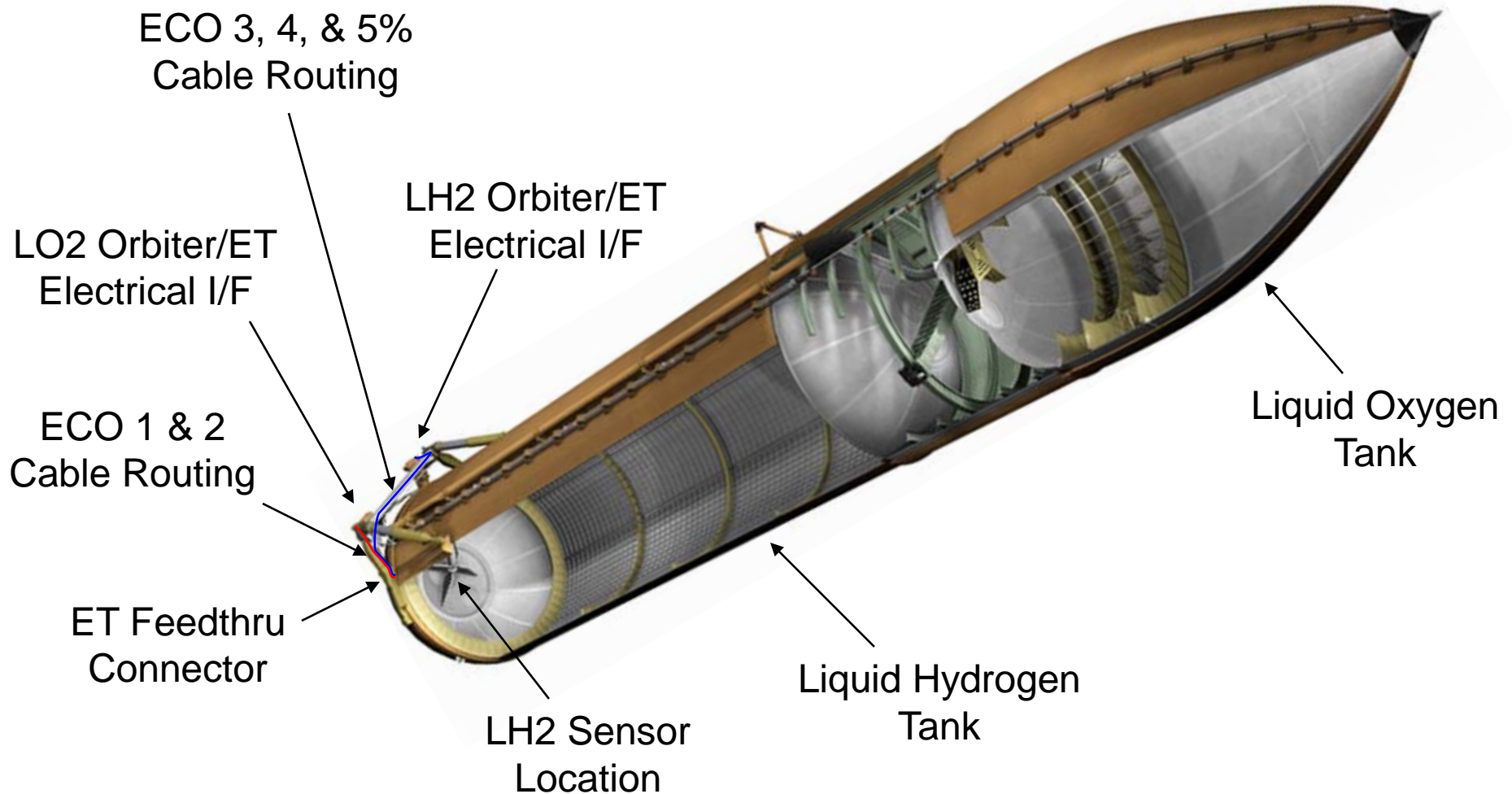



# Liquid Hydrogen ECO System

- The ET's LH2 sensors include cabling, harnesses, a series of connectors and Point Sensor Box (PSB) in the orbiter.
- The sensors in the tank basically consist of a platinum wire and support housing. Under cryogenic conditions the sensor's resistance drops from approximately 140 ohms (ambient) to approximately 5 ohms (-423 deg F). The PSB provides a constant current source which allows its electronics to monitor the voltage drop across each sensor for fuel status.
- There are four ECO sensors in the LH2 tank, mounted on a single, shock isolated carrier plate approximately four feet from the bottom of the tank.
- There are similar ECO sensors on the liquid oxygen side that are located in the Main Propulsion System LOX feed line inside the orbiter.

Overall Schematic of Engine Cutoff (ECO) and Liquid Level (Point) Sensors

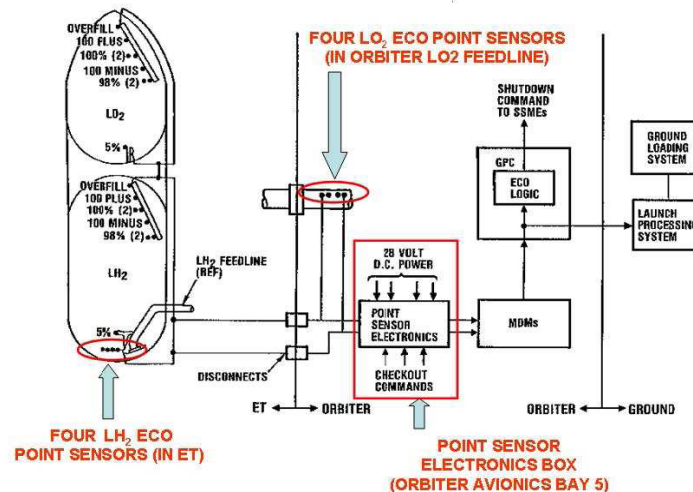

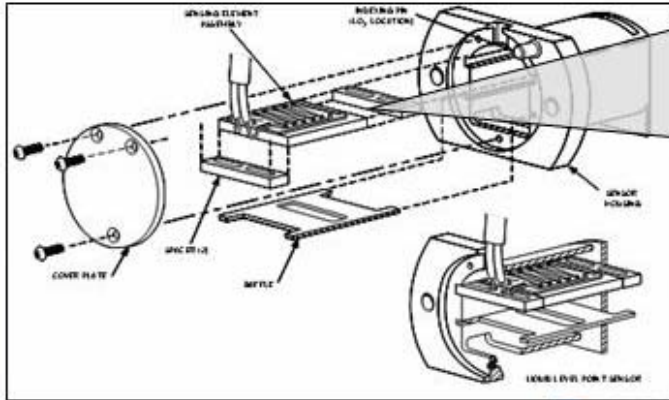

*Sensing Element*

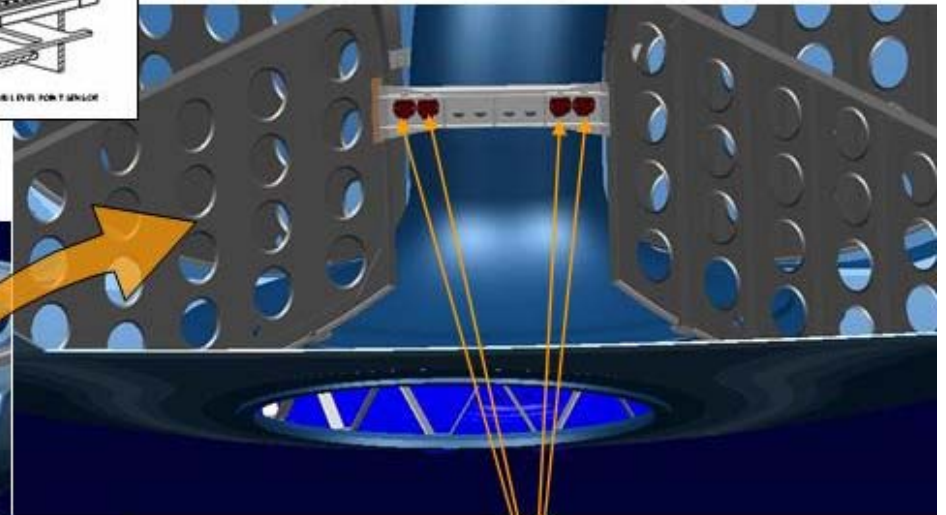
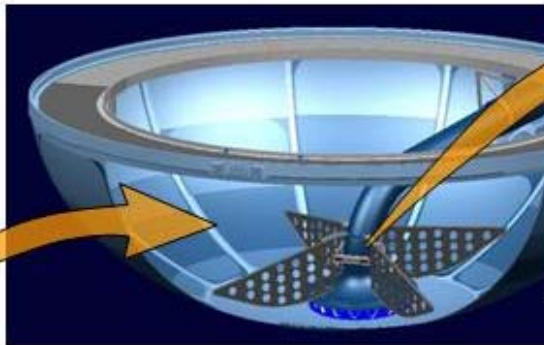

*Depletion Sensors  
Mounted on Shock Mount*

# Nominal Test and Checkout

- Shortly after propellant loading begins, the LH2 ECO sensors transition from 'dry' to 'wet,' meaning they are covered with cryogenic propellant. Shortly after the 5 percent sensor transitions to 'wet' propellant loading is commanded to Fast Fill and the PSB is commanded to a false 'dry' state (supplemental voltage test) for the LH2 ECO sensors. This configuration allows the PSB to monitor for a failed 'wet' (open circuit) condition.
  - This configuration keeps the sensors in the loop but tricks the PSB's comparator circuit to output a 'dry' indication. Since the sensors are still in the loop, the PSB will output a 'wet' indication if the circuit is interrupted (open circuit).
- This simulated 'dry' configuration is held until just after we enter the T-9 minute hold, when the command is removed and the sensors are monitored to assure that they are reading 'wet' through the remainder of the count.
- A vehicle modification to monitor each ECO sensor voltage drop is also available to assess systems performance.

# ECO Sensor History

- Prior to STS-114 numerous Liquid Level Sensor anomalies have been recorded. It wasn't until STS-114 where multiple ECO sensors were affected that a Common Cause concern was generated. Prior anomalies were either resolved or unexplained since the External Tank is/was unavailable post launch.
- STS-114, (ET-121), July 2005 – During tanking, ECO sensor #4 was discovered failed during the supplemental voltage test. During post scrub propellant drain, ECO sensor #3 also failed. An exhaustive engineering analysis and troubleshooting were performed without any significant findings (including an instrumented tanking test). The vehicle was rolled back to the VAB and transferred to a second stack. During the next launch attempt ECO sensor #2 failed. A 48 hour scrub was initiated to evaluate systems performance and test options. Launch occurred on July 26, 2005, without any ECO sensor issues.
- STS-121 (ET-119), July 2006 – The 5 percent Liquid Level Sensor was discovered failed during the supplemental voltage test. This sensor is not included in the in-flight Engine Cut-Off determination or criteria.
- STS-116 (ET-123), Dec 2006 -- ECO sensor #3 failed 'wet' during fast fill. A 24 hour scrub was initiated and the sensor recovered during drain. No sensor failures occurred during the subsequent launch.

- The launch of shuttle Atlantis on STS-122 was delayed in December of 2007 after failures occurred in the fuel sensor system while Atlantis' external tank was being prepared for launch.
  - The Dec. 6 launch attempt was postponed after two of the four LH2 tank ECO sensors gave false readings. Launch commit criteria requires four of four functioning sensors to lift off. A third sensor failed while the tank was drained of fuel. Within several hours of the tanking operation, all four ECO circuits returned correct readings.
  - On Dec. 9, one of the four LH2 ECO sensors gave a false reading, causing the launch to be postponed for the second time.

# Troubleshooting Plan



- Instrumented Tanking Test

Getting to the bottom of this anomaly was deemed critical to the future of the Program

- Requirements

- Quick Turnaround

- Minimize impact on Shuttle mission objectives

- Systems Characterization

- Identifying TDR responses to harness characteristics in advance was critical

- Failure Repeatability

- Previous anomalies did not consistently repeat during subsequent tankings
- However, the number of anomalies observed thus far for STS-122 yielded a high probability of capturing one during the tanking test.

- Characterization

- Fabrication and characterization of like 100 ft test cable.
  - Multiple TDR tests were performed in the lab to capture multiple cable configurations and responses.
- Test like External Tank
  - Multiple TDR tests were performed in the VAB on ET-126 utilizing the 100 ft Test Cable capturing the combined ambient responses.
- Testing under Cryo
  - Multiple TDR tests were performed at KSC's Cryo Lab utilizing the 100 ft Test Cable, an External ET Cable, Feedthru Connector, an Internal Cable, and Sensors to capture multiple cable configurations and responses in a Cryo environment.

- Summary:

System characterization responses were determined to be extremely consistent providing a high degree of confidence in the tests ability to localize any defect during the Tanking Test.

# Test Cable Routing and Setup

- View of MLP and Room 33A



50-2 Access Door

LO2 Tail Service Mask (TSM)

Test Cable Routing to 33A

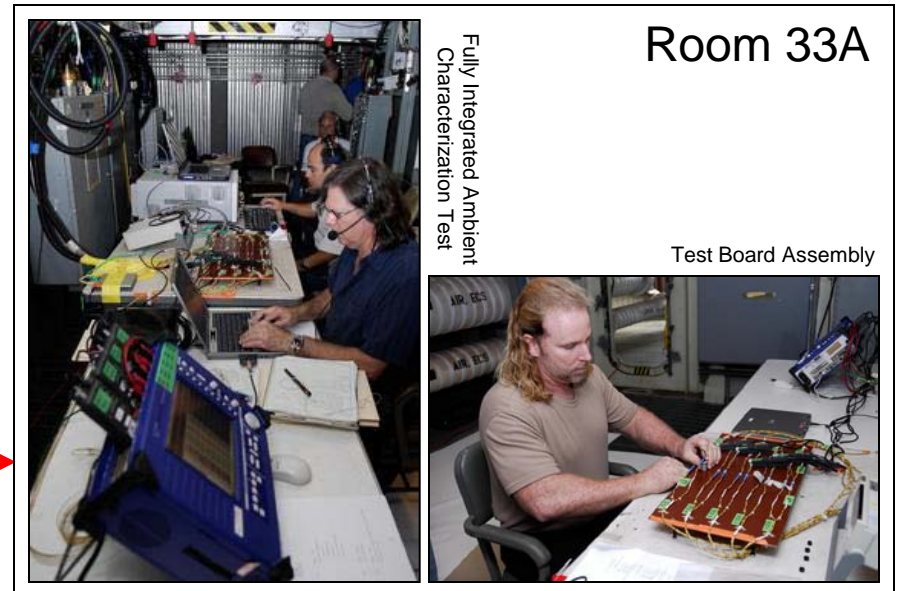

# LH2 ECO System Wiring Diagram

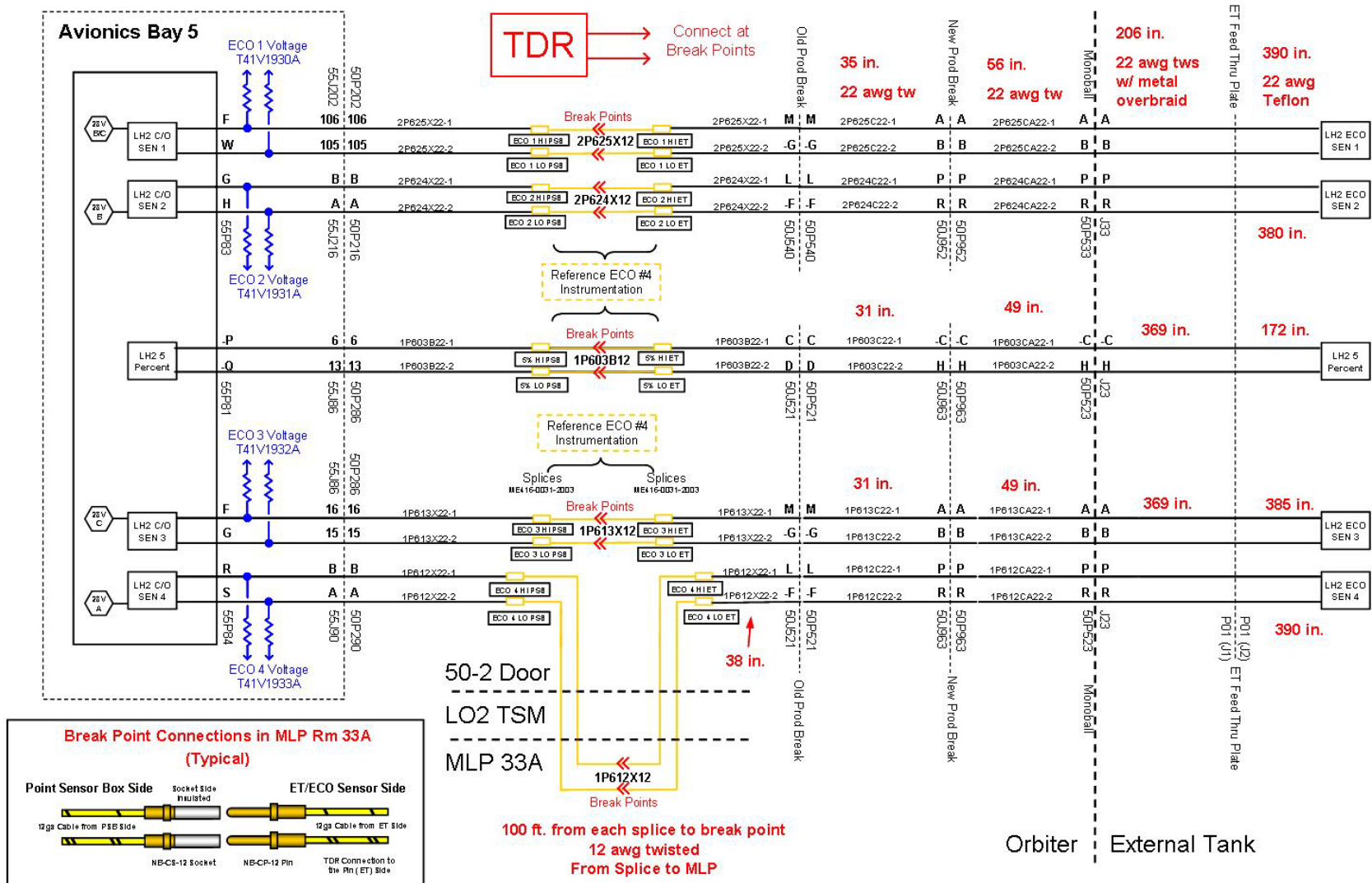

- A tanking, or fueling, test at Kennedy on Dec. 18, 2007, revealed that open circuits in the external tank's external electrical feed through connector were the most likely cause of false readings in the ECO sensor system during launch attempts on Dec. 6 and Dec. 9. NASA formed a combined troubleshooting team involving multiple NASA centers to find the root cause and develop plans to fix the system. A parallel team also was established to develop a forward plan of action to support the earliest possible launches STS-122 and STS-123.

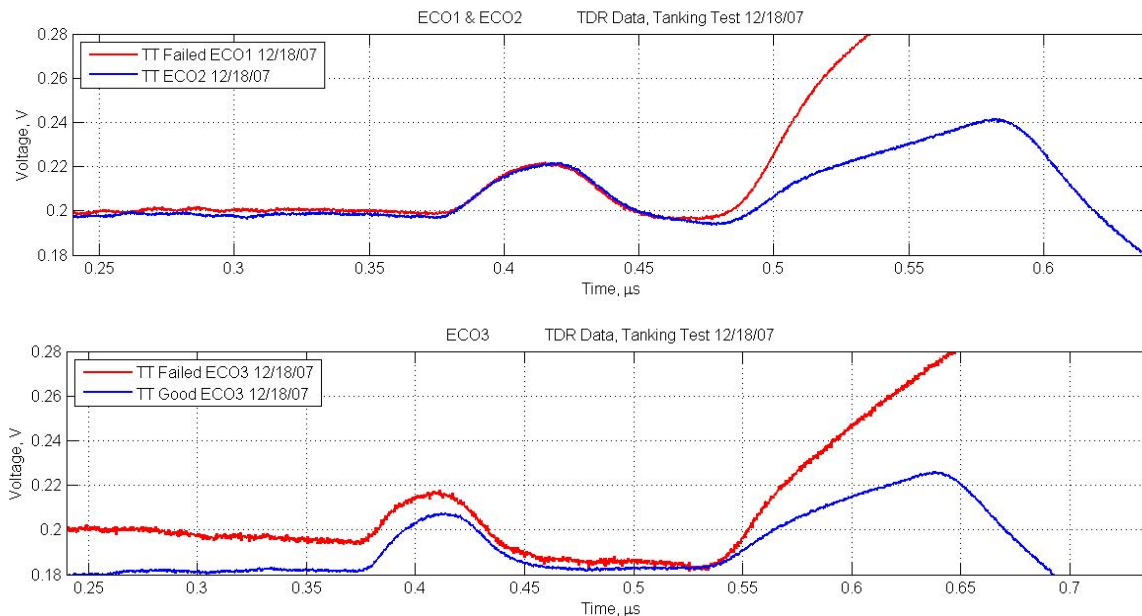

# Identifying Root Cause

- All circuit anomalies experienced during testing were able to be repeated as seen during the two launch attempts and tanking test.
- Open circuits in the part that connects wires from the interior to the exterior of the liquid hydrogen tank, commonly known as the feed through plate, were identified as the culprit that caused false readings during two launch attempts and a tanking test in December 2007.
- The external plug and feed through connector were removed from the tank and shipped to Marshall Space Flight Center in Alabama to determine whether the failure could be recreated in a test facility using focused and limited nondestructive and destructive physical tests. The tests were configured to replicate tank chill down temperatures, loading pressures and environmental conditions during the two launch attempts.



# Root Cause Analysis

- Additional testing at KSC Cryo Lab determined Liquid air / moisture combined with Krytox® and/or silicon oil residue can create a layer of frost under cryogenic conditions allowing for intermittent open circuits to form as subtle movements (thermal contractions) of the External Tanks external feed thru connector.
- Minute amounts of Krytox® and silicon were found on the external connector.
- The external connector is exposed to air and humidity while the internal connector is enclosed in the Helium purged LH2 tank.

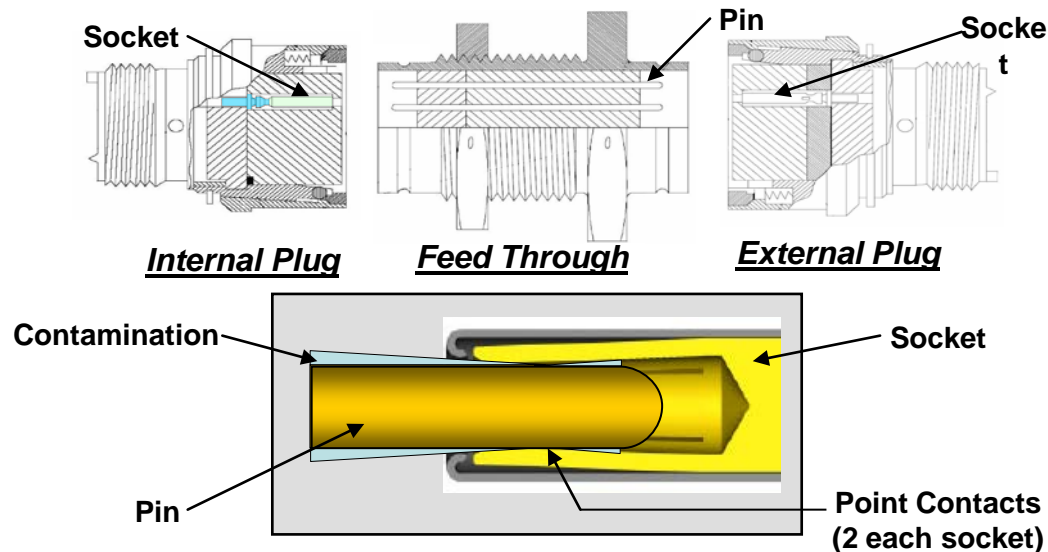



Objective is to contaminate pin (varying levels of contamination), insert into socket at ambient temperature then lower the mated pin/socket assembly into LN<sub>2</sub> bath then in a controlled fashion move the pin in/out of the socket while measuring the displacement and monitoring electrical characteristics.

Electrical characteristics monitored via Nicolet.

Data objectives:

1. Correlate anomalous electrical behavior to level of contamination.
2. Determine socket architecture affects if any (leaf spring vs. split tine).
3. Improve understanding of displacement required to get measurable electrical change.

4. Electrical characteristics of hard open (precursor behavior)

DIAL INDICATOR

PRECISION LINEAR RAIL

AJUSTMENT KNOB

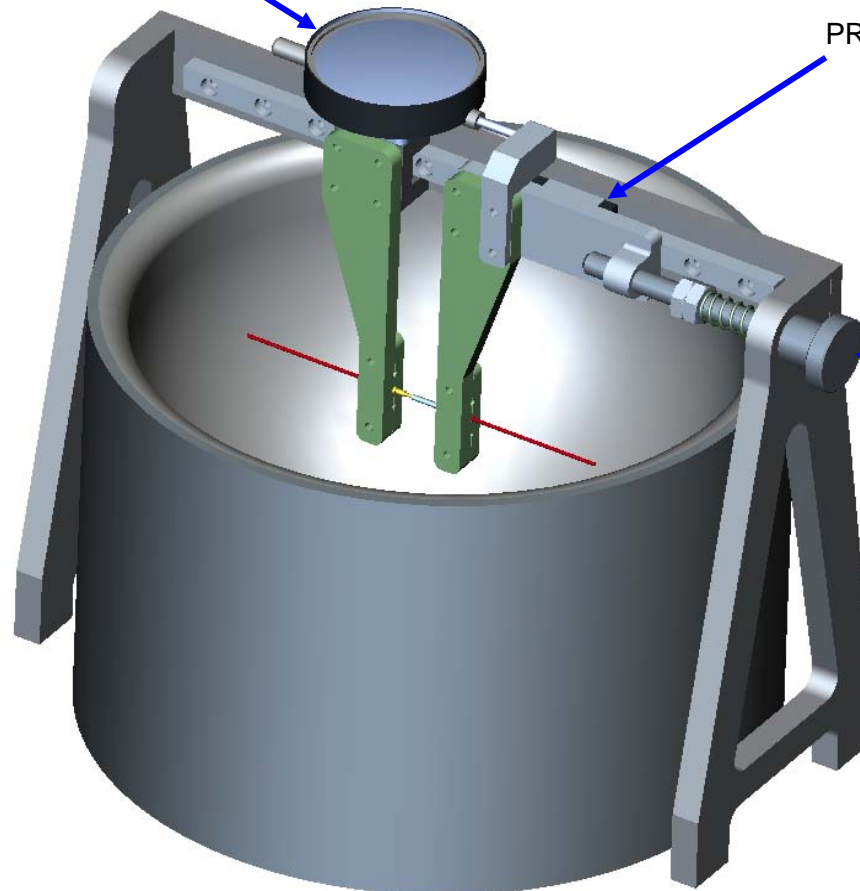

KSC Prototype Lab – Final Design

Electrical Characterization

- Resistance
- Current
- Voltage

Ambient Temperature

Wires are secured to the Cryogenic Wire Displacement Apparatus unmated.

Wires are connected to Nicolet. Pin and socket are mated to a 160 mil nominal insertion.

Cryogenic Temperature

Pin/socket assembly then cooled in LN2 for 1 to 3 minutes.

Wires are displaced out/in monitoring electrical data and displacement.

Anomalous electrical behavior and opens are noted with respect to displacement and contaminant condition (i.e. Krytox®, water, frost, Krytox®/water, or baseline/clean).

04/23/2008

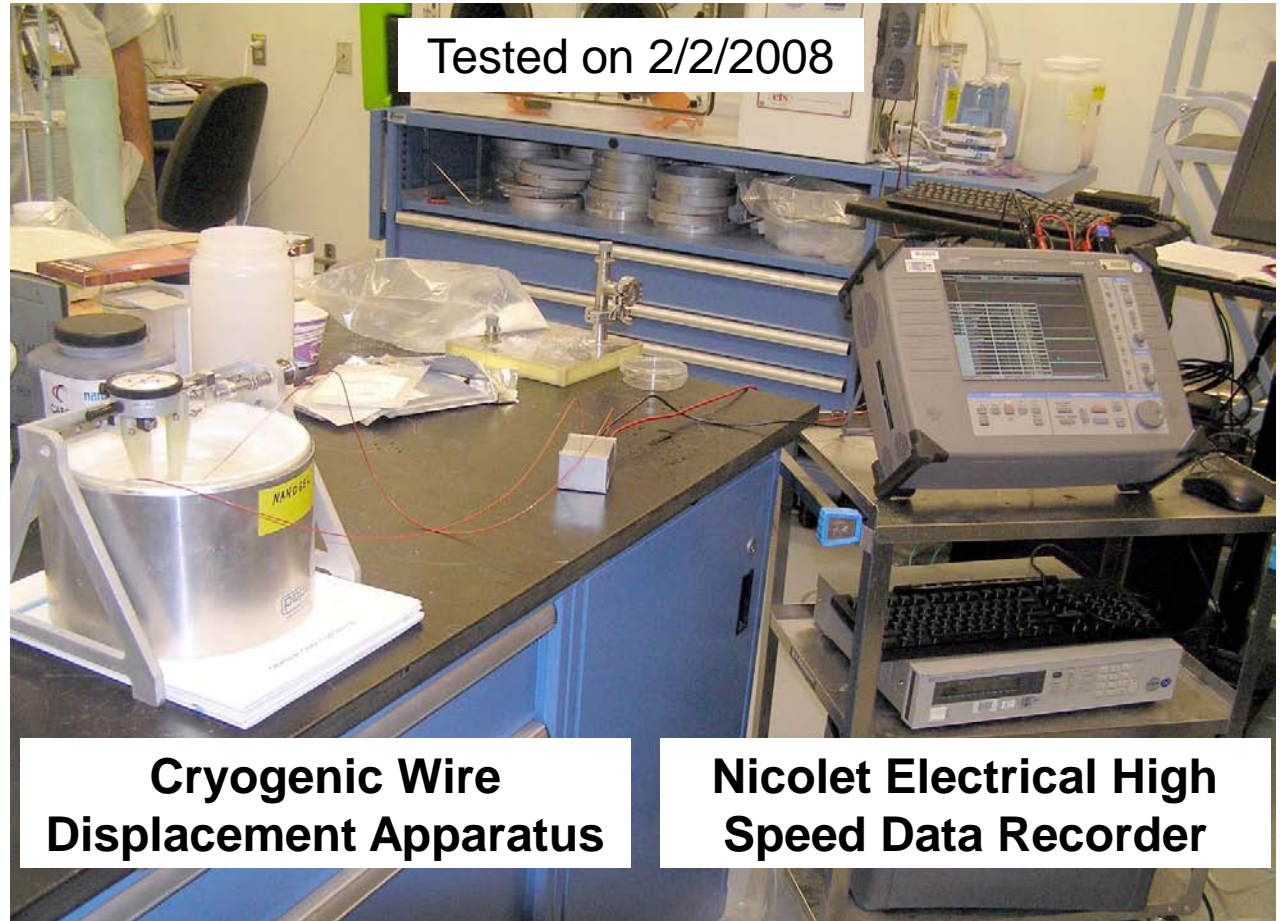

**Cryogenic Wire  
Displacement Apparatus**

**Nicolet Electrical High  
Speed Data Recorder**

Krytox®/water contamination is achieved by cooling engaged pin/socket in LN2 for 3 minutes then removing from LN2 and allowing frost/condensate to form engaged or disengaged or a combination thereof. Pin/socket is engaged 160 mils then placed back into LN2 for at least 3 minutes before displacement.

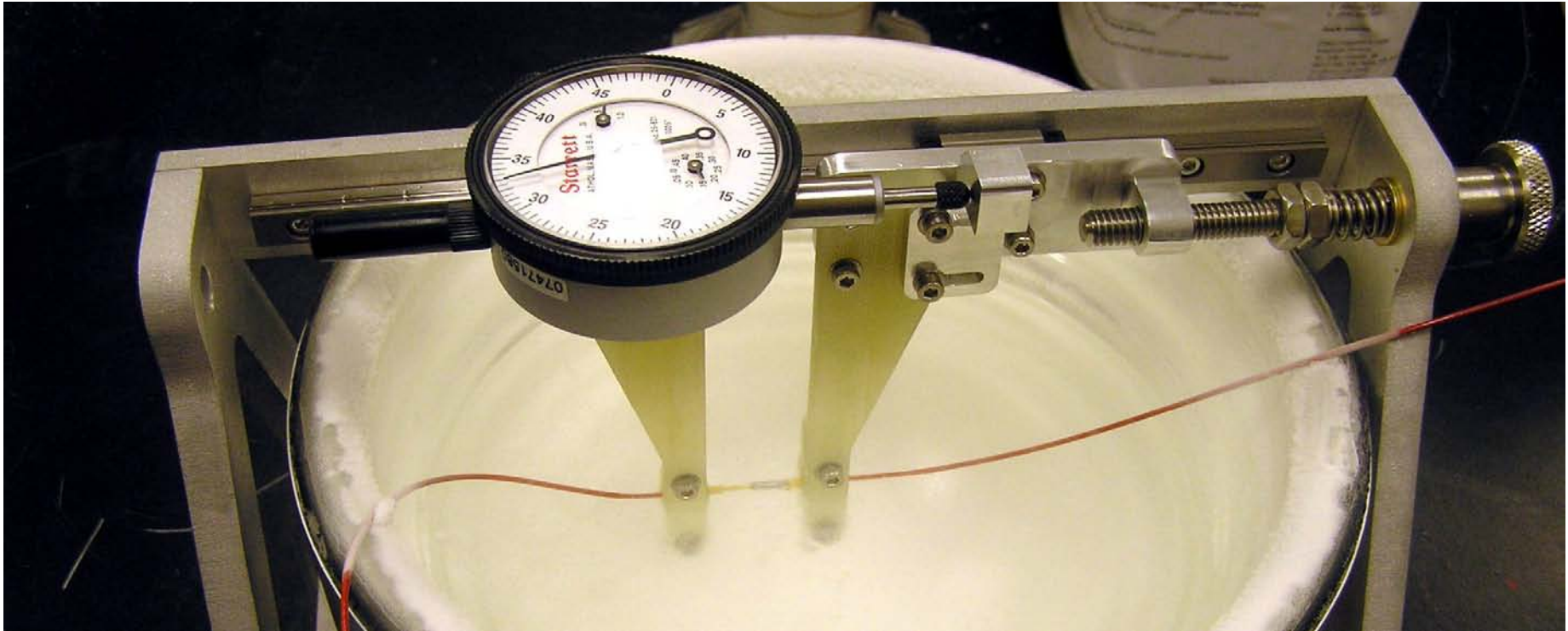

**Preliminary Results on Internal Double Tine Sockets**

Baseline (4)\*

No noise, no opens

Krytox® 240 AC Grease and Krytox® 143 AC (>6)\*

No noise (1 instance of min noise), no opens

Frost / Condensate (4)\*

Some noise, one short transient open

Krytox® / Water (2)\*

Noise precursor, mostly open (required about 1  
3 mils to initiate open)

Krytox® 240 AC + moisture

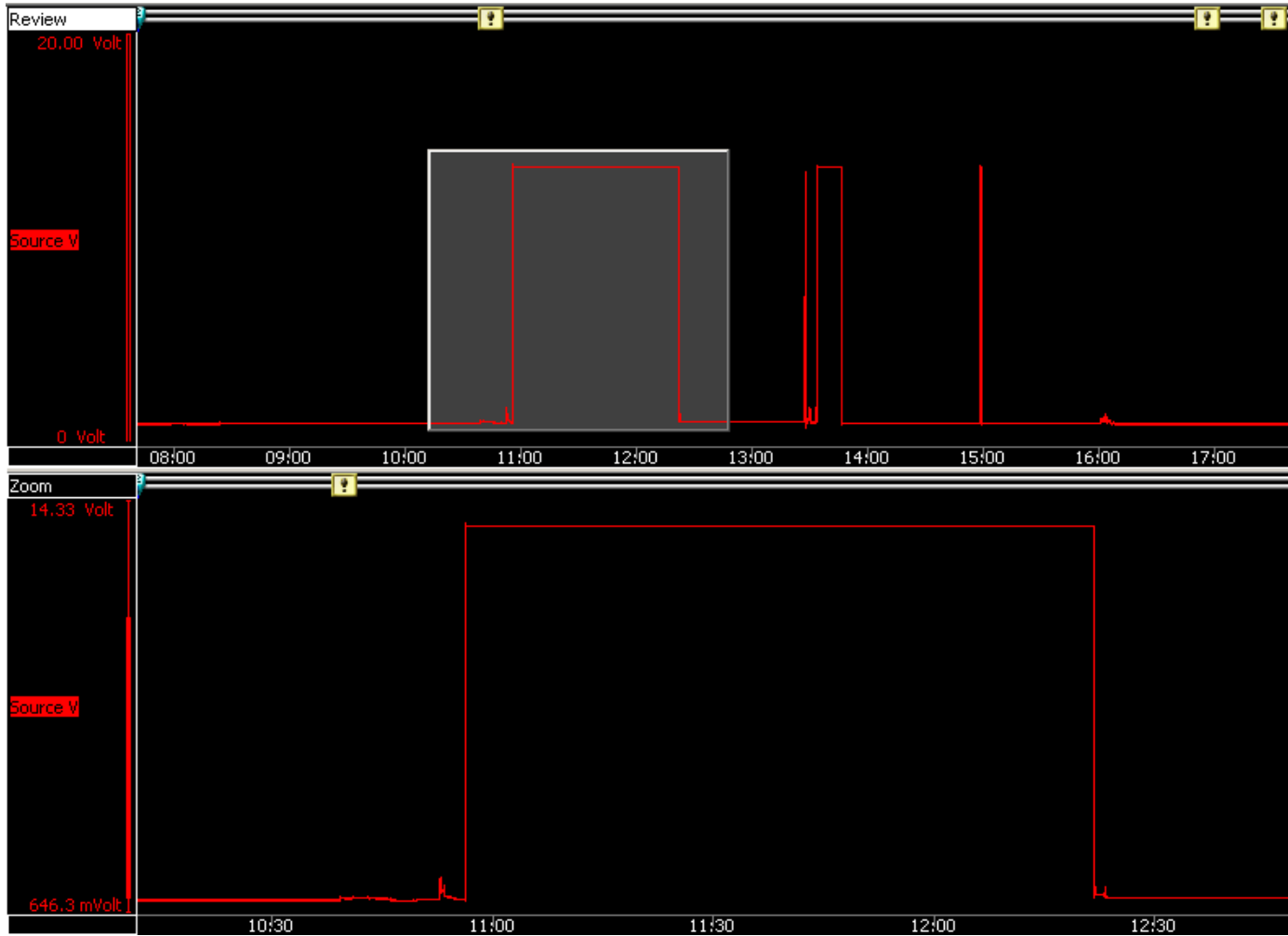

### Krytox® 240 AC + moisture

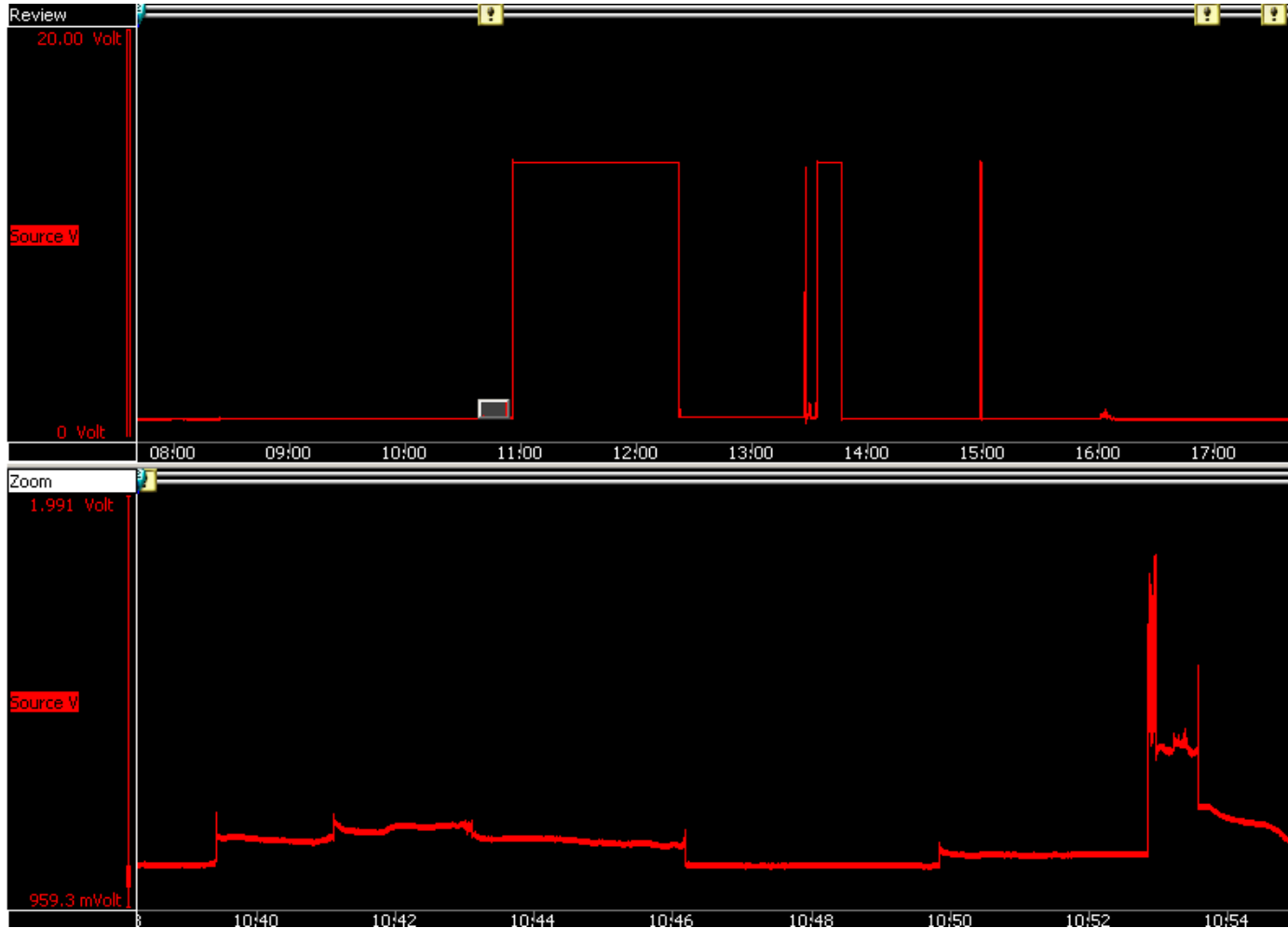

Moisture/water ONLY

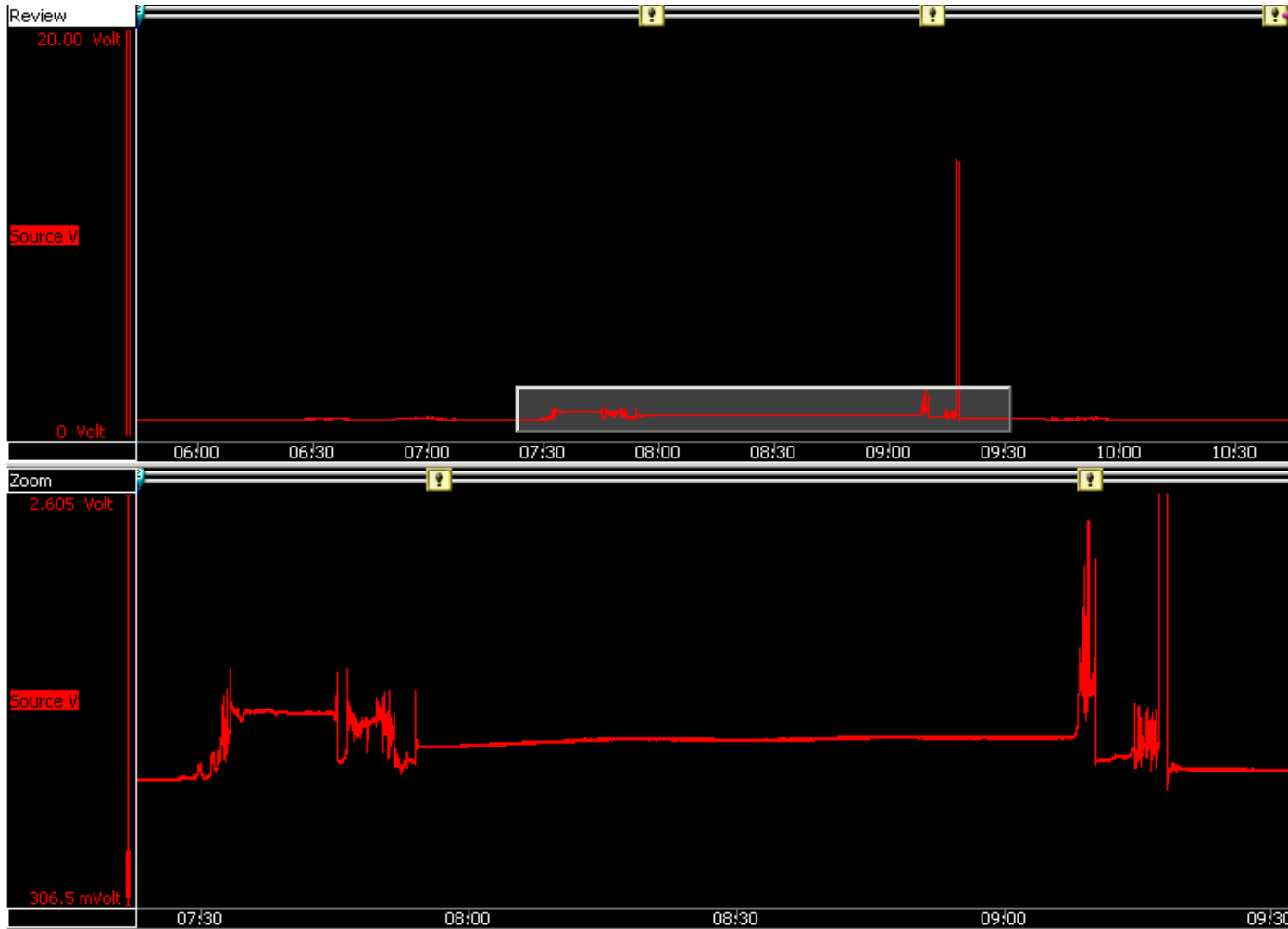

Moisture/water ONLY

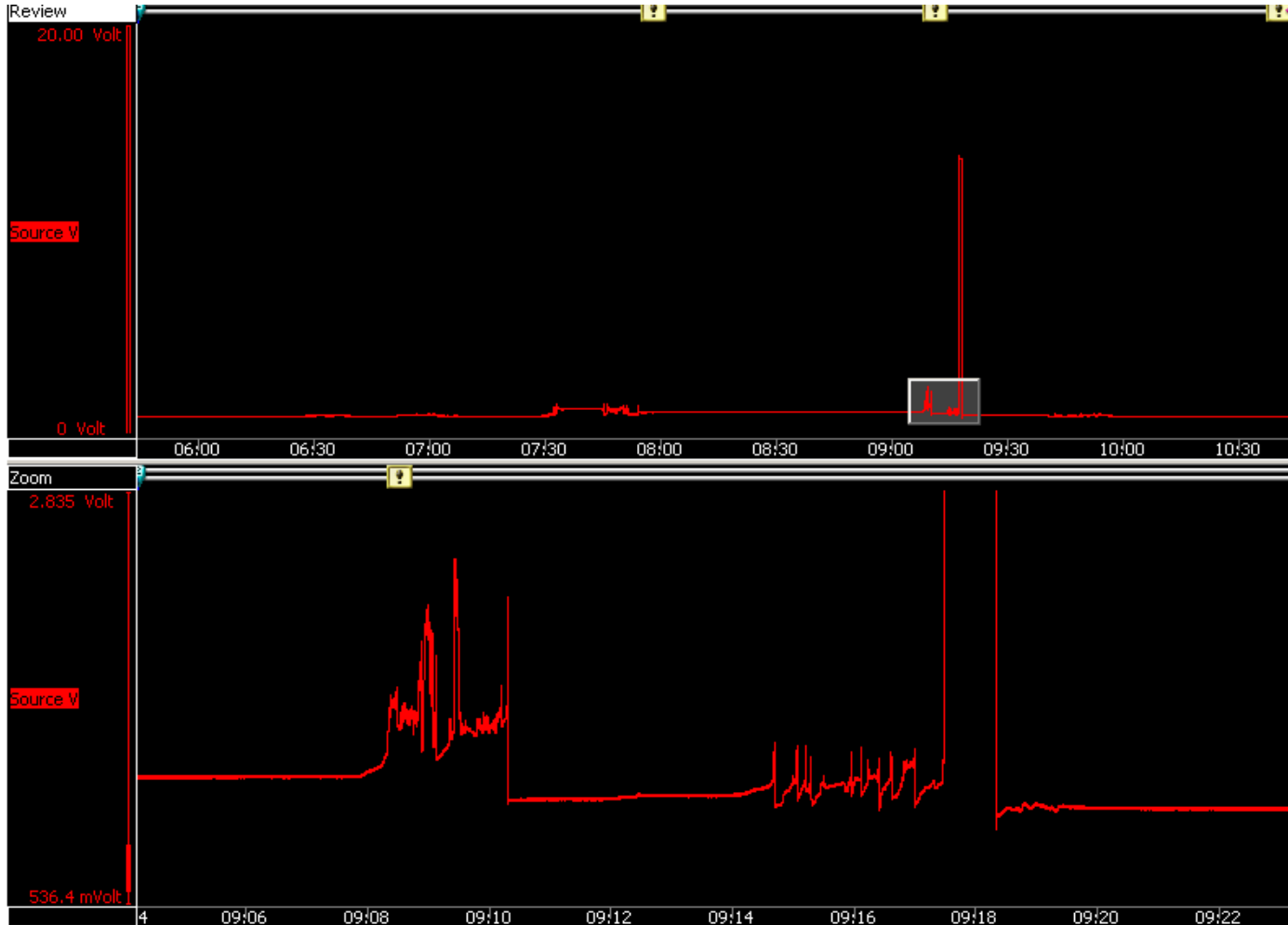

Krytox® 240 AC ONLY

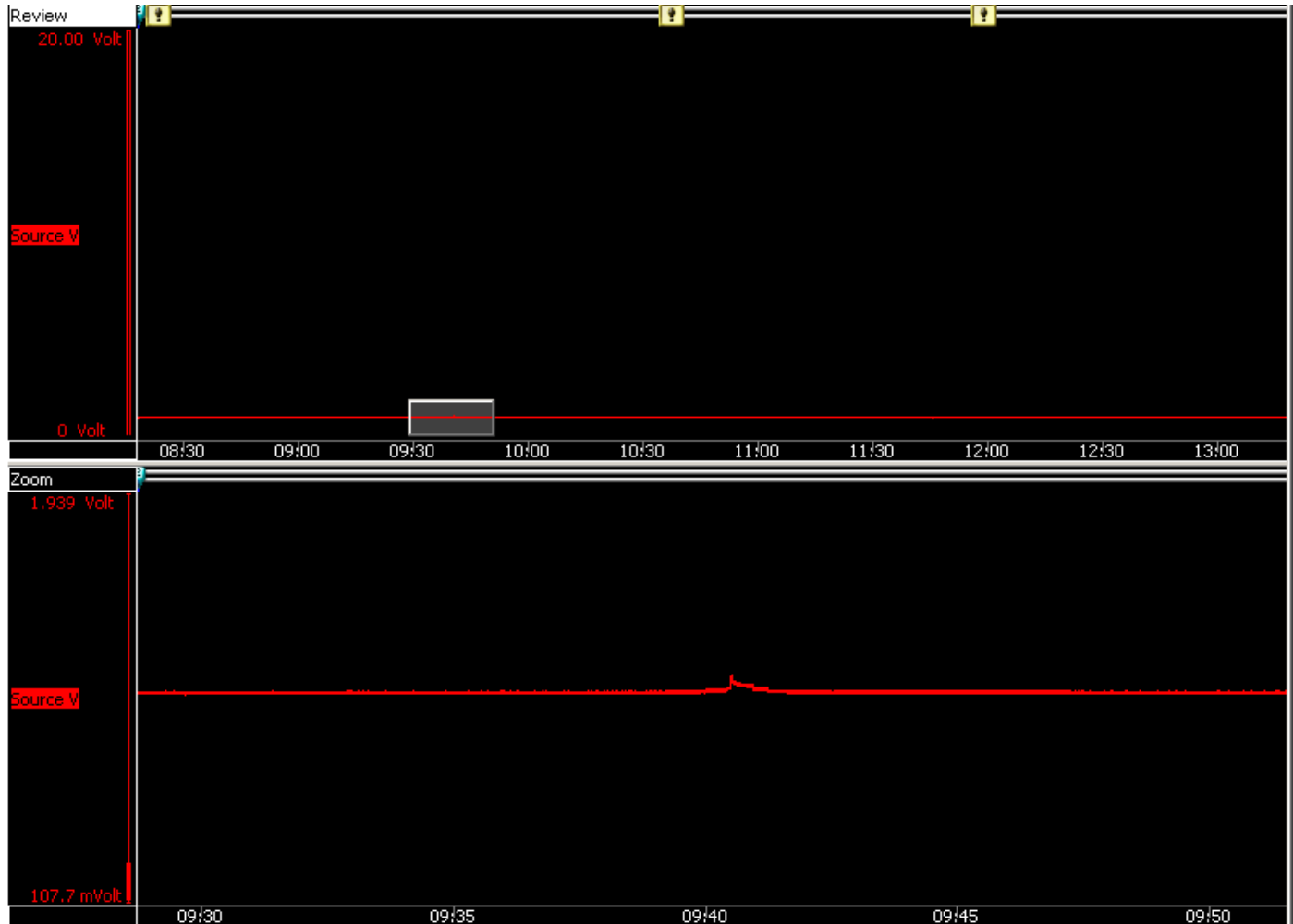



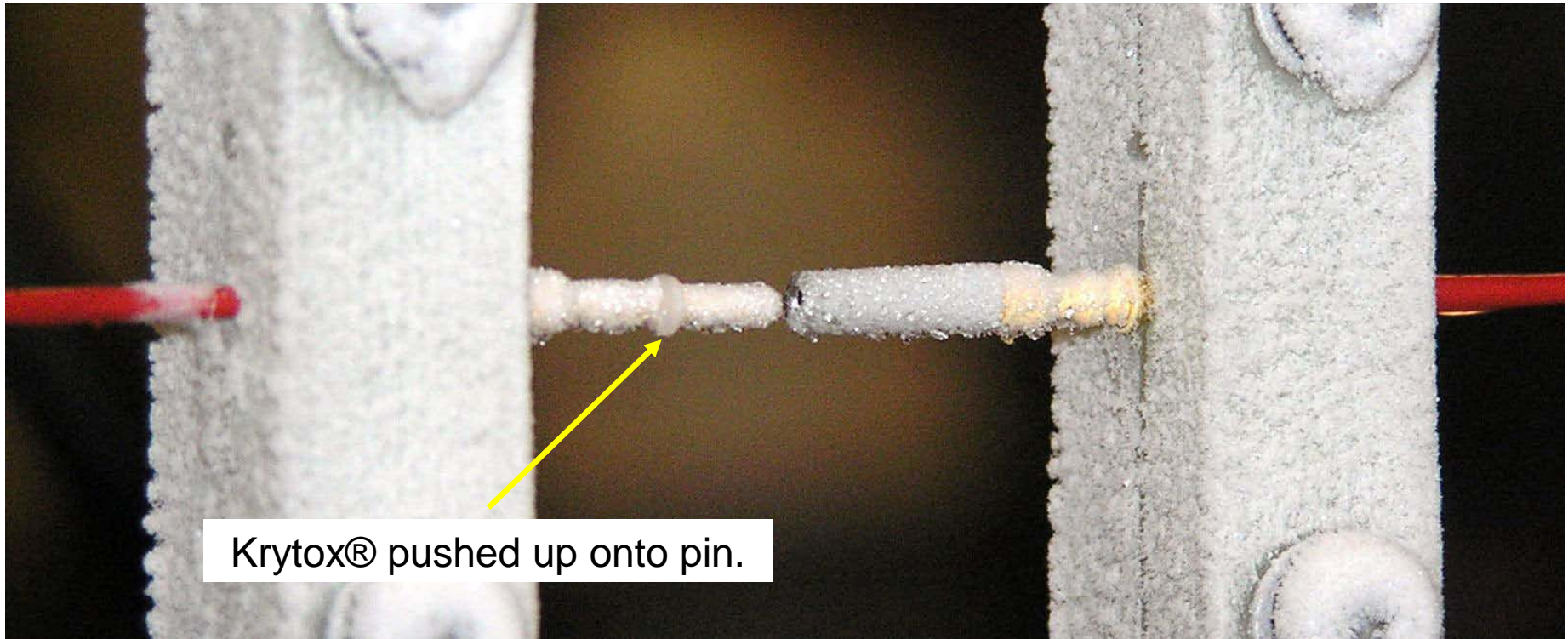

Frost formation on Krytox® 240 AC coated pin/socket after immersion in LN2 for at least 3 minutes beginning to melt.

One of the methods used to introduce moisture into pin/socket before test.

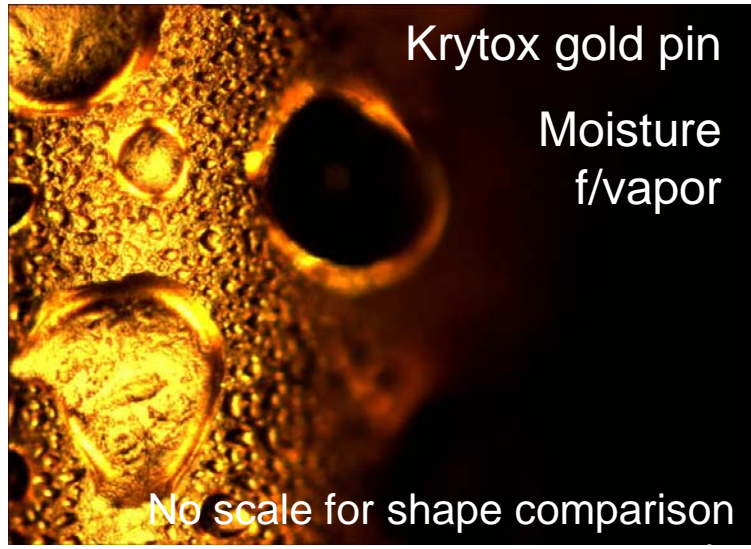
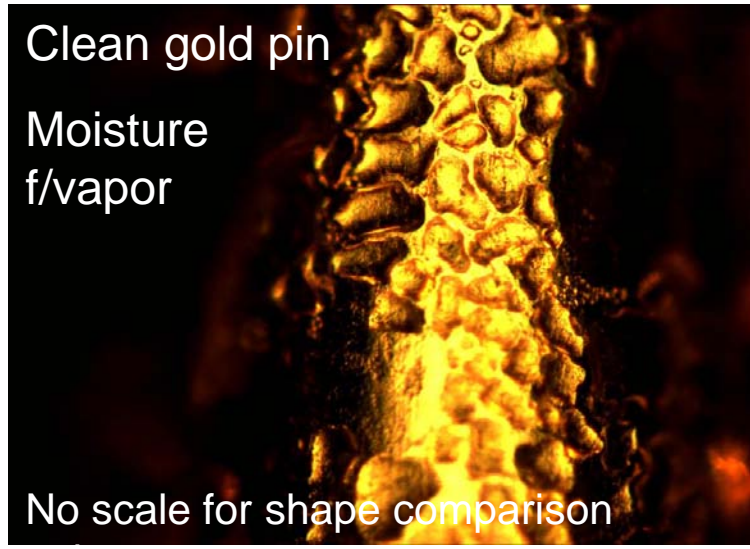

- “Clean” pin/sockets experienced no anomalous electrical behavior or opens when displaced in LN2.
- Water (frost/condensate) contaminated pin/sockets experienced some anomalous electrical behavior and one short transient open when displaced in LN2
- Krytox® (grease/oil) contaminated pin/sockets experienced no anomalous electrical behavior or opens when displaced in LN2.
- Krytox® 240 AC (grease) / water contaminated pin/sockets experienced a great deal of anomalous behavior and was mostly open when displaced in LN2. Krytox® 143 AC (oil) not run yet.
  - Krytox® 240 AC / water contaminated pin/sockets were heavily contaminated with Krytox®.

- Similar electrical behavior may be measured between other hydrophobic contaminants and water (i.e. silicone oil or organics).
- Anomalous electrical behavior and opens required cold and displacement.
- Electrical circuit reestablishes itself (open circuit closes) after the pin/socket system is removed from LN2.

- Preliminary test data supports flight rationale
  - Internal connector is in a purged environment prior to loading (no moisture present).
  - Internal connector has limited contamination in comparison to gross contamination of single pin/socket tests run to date.
- Supports root cause
  - Indicates a combination of contaminants may be required to increase the likelihood of experiencing anomalous electrical behavior and open circuits.
  - Displacement/movement and cold temperature is required for anomalous electrical behavior and to open circuit.

# Redesign

- A modified connector was designed with the pins and sockets soldered together. A similar, but slightly redesigned connector was to be used. Both the original and modified connector configurations were subjected to temperature, pressure and vibration environments identical to those experienced during a shuttle launch. The tests verified the adequacy of the new configuration.

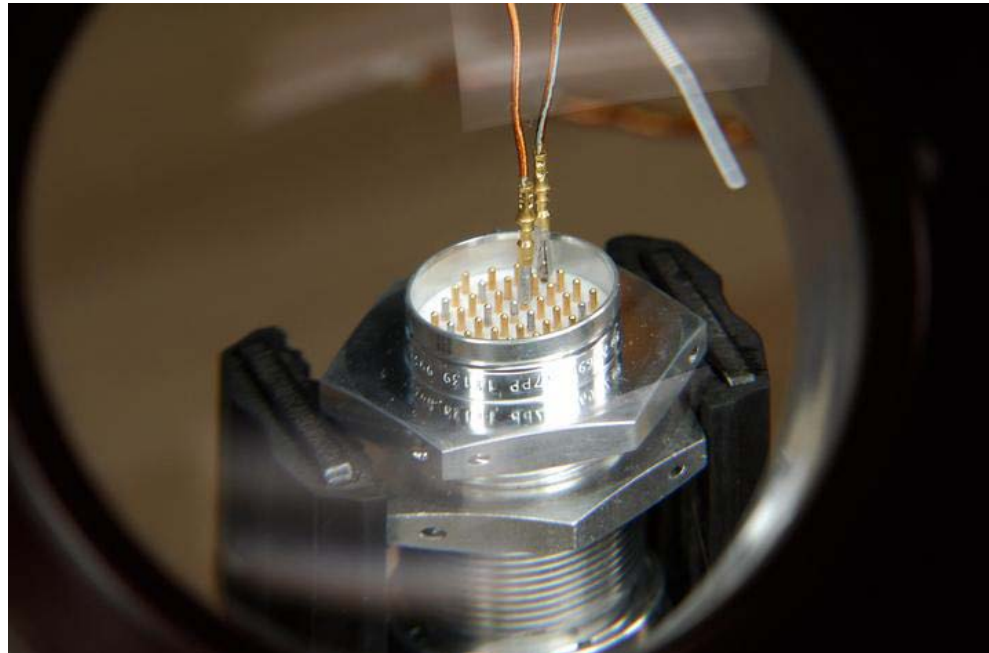

# Conclusion



- **Conclusion**
  - Liquid air / moisture combined with Krytox® and/or silicon oil residue can create a layer of frost under cryogenic conditions allowing for intermittent open circuits to form as subtle movements (thermal contractions) of the External Tank's external feed thru connector.
- **Resolution**
  - Solder the ten pin/socket connections (Four ECO and one 5 percent, both Hi and Low).
- **System Improvements**
  - Improved Tolerances on Sensors
  - Redundancy Routing / Separation
  - Voltage Monitoring Mod
  - Soldered Connections at the ET Feedthru External Connector